



DHV CONSULTANTS &
DELFT HYDRAULICS with
HALCROW, TAHAL, CES,
ORG & JPS

VOLUME 6
WATER QUALITY SAMPLING

FIELD MANUAL

Table of Contents

1	LABORATORY PREPARATIONS FOR SAMPLING	1-1
1.1	SAMPLERS	1-1
1.2	SAMPLE CONTAINERS	1-3
1.3	REAGENT SOLUTIONS	1-3
1.4	INSTRUMENTS	1-5
1.5	PLANNING	1-5
2	CHECKLIST FOR THE FIELD VISIT	2-1
3	SAMPLE COLLECTION	3-1
3.1	SAMPLE CONTAINERS	3-1
3.2	COLLECTING THE SAMPLE	3-1
3.2.1	MANUAL SAMPLING	3-1
3.2.2	PURGING AND SAMPLING	3-2
4	GUIDELINES TO BE FOLLOWED DURING SAMPLING	4-1
4.1	GENERAL	4-1
4.2	GROUNDWATER SAMPLING	4-1
4.3	SAMPLE IDENTIFICATION FORMS	4-2
4.4	SAMPLE LABELLING	4-2
4.5	SAMPLE PRESERVATION AND TRANSPORT	4-3
5	STANDARD ANALYTICAL PROCEDURES – FIELD DETERMINATIONS	5-1
5.1	GENERAL	5-1
5.2	COLOUR	5-1
5.3	ODOUR	5-1
5.4	TEMPERATURE	5-2
5.5	pH	5-2
5.6	ELECTRICAL CONDUCTIVITY (EC)	5-2
5.7	OXIDATION REDUCTION POTENTIAL (ORP)	5-3
6	GUIDELINES ON STANDARD ANALYTICAL PROCEDURES	6-1
	APPENDIX A STANDARD ANALYTICAL PROCEDURES	A-1
	APPENDIX B SPECIFICATIONS FOR SUBMERSIBLE PUMPS	B-1

1 LABORATORY PREPARATIONS FOR SAMPLING

A sampling campaign needs many preparations to be made at the laboratory where the bulk of the analyses are being carried out, i.e. in the Level II/II+ laboratory. These preparations are required with regard to the following :

- Sampler
- Sample containers
- Reagent solutions
- Instruments
- Ice box with ice

1.1 SAMPLERS

The preferred type of sampler in the field for groundwater sampling is the submersible pump. The sampler should be cleaned and rinsed. Sampler should also be briefly checked for functioning, closing of caps, if applicable, and condition of the cable by which the submersible pump will be lowered inside the well.

To take a representative sample, the sampling procedure should meet the following requirements:

- allows removal of stagnant water from the well (called purging) by means of a submersible pump so that the sampled water represents the water in the aquifer;
- avoids degassing of the sample and volatilisation of components in it;
- prevents oxidation caused by contact with the atmosphere, and
- avoids contamination of the sample and the well.

Three conventional methods and one sophisticated technique are reviewed briefly with respect to their capability of providing representative samples as follows:

Conventional Techniques (not recommended under HP)

1. **Bailers or depth samplers** are the grab samplers that operate by lowering the device to a known depth in the water column, closing the valve at the bottom and raising it to the ground surface. Major limitation is the high atmospheric contact during sampling. Furthermore, bailers are difficult to clean (dead-volumes) and the risk of cross-contamination from one well to another (cross-contamination) is high. In addition, contamination of the well water during sampling can be foreseen when a large bailer scrapes the casing of small diameter wells. Purging of the well before sampling by the use of bailers is very time-consuming.
2. **Suction devices** lift the water sample by applying suction directly to the water or via a collection bottle. Suction can either be generated manually or by a pump (e.g. peristaltic or centrifugal type) but the sampling depth is limited to 8 or 10m. The major limitation is degassing and aeration that cannot be controlled. As with bailers, effective purging is very time-consuming using suction devices.
3. **Gas-driven devices** apply gas (air) creating positive pressure directly on the water that drives it from the borehole - back flow being prevented by check valves. Usually compressed air is pumped down the borehole through a delivery tube. The air then forces water up through a second tube (acting as an airlift pump) and the air water mixture emerges at the head of the well. The intense contact between high-pressure air and the water causes oxidation and disturbance in the dissolved gas balance of the waste water, namely, degassing and volatilisation, which in turn can cause precipitation of contaminants. This will mean that the sampled water is no longer representative of the groundwater from which it is taken.

Sophisticated Technique (recommended under HP):

4. **Submersible pumps** are lowered into the borehole and water is driven out continuously at the surface. The following three principles are used to drive out the water: gears or rotor assembly (electric centrifugal pump), gas-operated plunger (piston pump) or a gas operated diaphragm (bladder pump). Submersible pumps of these three types are rated acceptable for sampling groundwater for all parameters, including volatile organic carbon, trace metals and dissolved gasses and is therefore recommended as the lifting device for the current water quality programme under HP.

If a submersible pump is used to obtain water samples from boreholes, it should ideally have the following characteristics (See Appendix B):

- **Variable pumping rate:** The capacity assessment has been calculated in Appendix A. A variable pumping rate is also necessary to allow high speed for rapid purging and slower speeds for sampling (less than or equal to 0.1L/min).
- **Size:** The outer diameter of the pump should be considerably less than the smallest inner diameter of the boreholes or piezometers in the monitoring programme. A gap of at least 3cm is needed all around to guarantee that the pump does not scrape/damage the sides of the wells during lowering and lifting. The smaller the pump compared to the inner diameter of the well, the easier the lowering and lifting will be. If the well is equipped with a digital water level recorder (DWLR), it is recommended that the DWLR is removed before insertion of the submersible pump to avoid physical damage to the equipment, tubes or cables.
- **Material:** The material of the pump, tubing and fittings (all parts that make contact with the well water) should be inert and resistant to corrosion. The most common material used is stainless steel.
- **Power supply:** A portable power generator set together with an adjustable frequency converter (to regulate the pumping speed) is required.
- **Portability:** The weight and size of the complete set of generator and accessories should be such that it could be easily transported even through off-road terrain. A lighter set is easier to handle and will increase the ease and speed of transportation and positioning.
- **Noise:** The noise level of the sets should be acceptable and for this purpose an exhaust silencer with muffler is advised.
- **Cleaning:** The pump and the tubes must be easy to clean (no 'dead-volumes') in order to avoid cross-contamination of wells.
- **Maintenance and repair:** The pump must be easy to repair in the field and all tools and spare parts must be included with the portable set.
- **Accessories:** A water level indicator and a field kit mounted with probes for analysing/monitoring parameters, like temperature, pH, conductivity and ORP are worth considering.

For manual sampling of hand-dug wells (which cannot be purged) all that is required is a weighted sampling can with a rope attached to its handle (Figure 1). The can is then carefully lowered down the well until it fills with water and is then brought out of the wall. Although virtually any style of sampling can is acceptable for this application, there are a number of features that are preferable as follows:

- **Small volume and diameter:** It is preferable that the sampling can has a relatively small volume and diameter. This makes it easier to haul the can up the well when it is full of water and helps to ensure that the can does not touch the sides of the well.
- **Plastic:** This makes the sampling can lighter, easier to clean and less likely to chemically react with the parameters to be determined in the water sample. For the same reasons the rope attached to the bucket should also be made of a synthetic fibre.
- **Lipped:** The provision of a lip to the sampling can makes pouring the water into a sample bottle much easier.

1.2 SAMPLE CONTAINERS

The sample containers for the water quality sampling need to be checked in the laboratory by the laboratory staff and given to the person conducting sampling.

The number of containers and the type of containers needed for the water quality sampling needs to be determined based on the number of sites to sample and the parameters selected for monitoring. In the design-phase of the monitoring programme, the sampling locations, and the type of sampling location (baseline, trend, surveillance etc.) is determined, which gives the frequency of sampling and the parameters for analyses.

In order to cover the range of parameters, which need to be sampled and analysed, a variety of sample containers are used. Table 1.1 gives the required type of container and the suggested volume of sample for most common parameters. Note that containers made of either glass or polyethylene are recommended, containers made of PVC plastic are not recommended.

Bottles which are to be used for the samples must be thoroughly washed and then rinsed with distilled water before use. Bottles which are to be used for microbiological samples must be thoroughly washed and sterilised before use. Sterilising can be carried out by placing the bottles in an autoclave at 121°C for fifteen minutes or, if the caps of the bottles do not contain plastic or rubber materials, in an oven at 170°C for at least two hours. Bottles to be used for pesticides samples are to be rinsed with organic solvent (e.g. hexane) prior to use. This should be done in the laboratory.

All bottles should be checked to see if the (screw) caps and seals close properly. Labels for the sample bottles should be prepared or special pens for labelling the bottles should be used. Making a list of sample containers per site will ensure that the right number and type of containers are brought to the field. Always bring a few extra containers in case of unforeseen events.

1.3 REAGENT SOLUTIONS

For some of the field analyses, reagent solutions are necessary for the analysis. All necessary reagent solutions should be freshly prepared in the laboratory and brought to the field by the sample collector.

Refer to the '*Guidelines on Standard Analytical Procedures for Water Analyses, May 1999*' for detailed procedures on preparation of reagents. Relevant procedures are given in Appendix A.

For analysis of pH, buffer solutions are necessary to standardise the pH meter: Buffer solutions should be prepared in the laboratory, or purchased, for pH = 4, 7, and 9.

For analysis of Electrical Conductivity, standard potassium chloride solution, KCl (0.01M) is needed to standardise the conductivity meter.

For preservation of certain samples, concentrated nitric acid, concentrated sulfuric acid, ZoBell's solution etc. are needed.

A supply of distilled water is needed for rinsing equipment.

Parameter Group	Parameter	Sample Container (See note below)	Sample Pre-treatment (See note below)
General	Temperature	On-site analysis	On-site analysis
	Suspended Solids	1	None*
	Conductivity	On-site analysis	On-site analysis
	pH	On-site analysis	On-site analysis
	oxidation reduction potential	On-site analysis	On-site analysis
	Dissolved Solids	1	None*
Nutrients	Ammoniacal Nitrogen	3	7
	Total Oxidised Nitrogen	3	7
	Ortho Phosphate	4	None*
Organic Matter	Chemical Oxygen Demand	3	8
	Biochemical Oxygen Demand	2	4°C, Dark
Major Ions	Sodium	3	None*
	Potassium	3	None*
	Calcium	3	None*
	Magnesium	3	None*
	Carbonates and Bicarbonates	1	None*
	Chloride	1	None*
	Sulphate	1	None*
Other Inorganics	Silica	1	None*
	Fluoride	1	None*
	Boron	1	None*
Metals	Cadmium	3	8
	Mercury	4	8
	Zinc	3	8
Organics	Pesticide (Indicator)	5	4°C, Dark
	Synthetic Detergents	1	None*
	Organic Solvents	1	4°C, Dark
	Phenols	5	7
Microbiological	Total coliforms	6	4°C, Dark
Biological	Chlorophyll 'a'	1	4°C, Dark
<p>NOTES:</p> <p><i>Containers:</i></p> <ol style="list-style-type: none"> 1000 millilitre polyethylene bottle Special BOD bottle (normally 300 millilitre) 500 millilitre polyethylene bottle 100 millilitre glass bottle 1000 millilitre glass (or Teflon) bottle with Teflon lined caps Strong thick-walled, screw-capped glass bottle (300 millilitre capacity). Only good quality will maintain a good seal after multiple sterilisations in an autoclave <p><i>Preservation:</i></p> <ol style="list-style-type: none"> Samples should be acidified with 2 ml of concentrated sulphuric acid Samples should be acidified with 2 ml of concentrated nitric acid. <p>*None: Ideally, <i>all</i> samples should be kept cool and in the dark after collection. If this is not possible, then at least samples for BOD, coliforms, chlorophyll, pesticides and other organics that are likely to volatilise MUST be kept at 4°C, and dark. Remaining samples can have no preservation.</p>			

Table 1.1: Water Quality Parameters - Sampling Containers and Pre-treatments Required

1.4 INSTRUMENTS

Some instruments and equipment are necessary to make the field analyses. Instruments and equipment must be brought to the field. *Temperature should always be measured in the field:*

- For measurement of Temperature, a (mercury) thermometer or thermistor is needed.
- For analysis of Electrical Conductivity, a conductivity meter is needed.
- For analysis of pH, a pH meter is needed.
- For analysis of Redox Potential, a pH meter (mV scale), reference electrode and oxidation-reduction indicator electrode are needed.

Note: It is possible that instead of separate meters for temperature, pH and conductivity, there is a single instrument with different probes, which will measure all three parameters. These are called field-monitoring kits.

A supply of batteries and standard spare parts should also be carried along with the field instruments.

1.5 PLANNING

When planning a sampling programme, the maximum number of wells that can be sampled in one day must be known. This will help to know the time needed for sampling, and other actions required at the site. Since purging is a time-consuming activity, an estimate of the purging time is a must to arrive at a fair estimate of the sampling time required. See the top part of Table 5, called 'office well data', where the projected time of purging is estimated.

2 CHECKLIST FOR THE FIELD VISIT

Table 2.1 contains a list of items which should be checked before starting on a sampling mission. At least one day before sampling, make sure that all the arrangements are made as per the check list.

Make sure that you know how to reach sampling site(s). Take help of location map for each site which shows the sample collection point with respect to prominent landmarks in the area. In case there is any deviation in the collection point, record it on the sample identification form giving reason.

Note that depending on the local conditions, type of water body, analysis requirements etc., not all items on the checklist may be necessary. Other items, not listed, may sometimes be required. The field operator may make his or her own personal checklist based on Table 2.1.

Decide on the number of each item that would be required depending on the number of samples to be collected. It is always safer to carry a few numbers in excess.

If for any reason the laboratory conducting analyses is different from the laboratory preparing sample bottles, ensure that the concerned laboratory is informed of the programme and ready to receive samples, particularly those, which would need immediate storage in refrigerator/analyses.

<ul style="list-style-type: none"> Itinerary for the trip (route, stations to be covered, start and return time) 	<ul style="list-style-type: none"> Personnel and sample transport arrangement
<ul style="list-style-type: none"> Area map 	<ul style="list-style-type: none"> Sampling site location map
<ul style="list-style-type: none"> Icebox filled with ice or icepacks or ice 	<ul style="list-style-type: none"> Weighted bottle sampler
<ul style="list-style-type: none"> BOD bottles 	<ul style="list-style-type: none"> Rope
<ul style="list-style-type: none"> Special sample containers: bacteriological, heavy metals etc. 	<ul style="list-style-type: none"> Sample containers
<ul style="list-style-type: none"> Sample preservatives (e.g. acid solutions) 	<ul style="list-style-type: none"> Thermometer
<ul style="list-style-type: none"> Tissue paper 	<ul style="list-style-type: none"> Other field measurement kit, as required
<ul style="list-style-type: none"> Sample identification forms 	<ul style="list-style-type: none"> Labels for sample containers
<ul style="list-style-type: none"> Field notebook 	<ul style="list-style-type: none"> Pen / pencil / marker
<ul style="list-style-type: none"> Soap and towel 	<ul style="list-style-type: none"> Match box
<ul style="list-style-type: none"> Spirit lamp 	<ul style="list-style-type: none"> Torch
<ul style="list-style-type: none"> Drinking water 	<ul style="list-style-type: none"> Knife
<ul style="list-style-type: none"> First-aid box 	<ul style="list-style-type: none"> Gloves and eye protection
<ul style="list-style-type: none"> Dummy sampler to check well conditions 	<ul style="list-style-type: none"> Submersible pump and accessories

Table 2.1: Checklist for Field Visit

3 SAMPLE COLLECTION

3.1 SAMPLE CONTAINERS

The sample containers needed for a sampling campaign are prepared by the laboratory and given to the person collecting the samples. An overview of the types of containers and preservation is given in Table 3.1. More detailed information on the specific containers needed for each parameter is given in Table 1.1.

	Analysis	Container	Volume (mL)	Preservation
0	On-site analysis	PE bowl or container	±200	-
1	General (SS, TDS, major ions, chlorophyll-a)	Glass, PE	1000	-
2	COD, NH ₃ , NO ₂ ⁻ , NO ₃ ⁻	Glass, PE	500	H ₂ SO ₄ , pH <2
3	O-PO ₄	Glass	100	-
4	BOD	Glass, PE	1000	4°C, Dark
5	Coliforms	Glass, PE, Sterilised	300	4°C, Dark
6	Heavy metals (Cd, Zn)	Glass, PE	500	HNO ₃ , pH <2
7	Mercury	Glass	1000	HNO ₃ , pH <2
8	Pesticides	Glass, Teflon	1000	4°C, Dark

Table 3.1: Container Types and Volumes needed for Sampling

3.2 COLLECTING THE SAMPLE

3.2.1 MANUAL SAMPLING

If a sampling can or a bailer is used to take manual samples from hand-dug wells, the sampling device should be rinsed out several times with the water to be sampled before any bottles are filled. Each sample bottle should be similarly rinsed out before filling.

In order to prevent samples from degrading and giving false analytical results, it is necessary to chemically pre-treat some samples as soon as they are obtained. Also, many parameters require particular sample containers for the same reason. Table 3 gives the type of container that should be used and the pre-treatment method required for each proposed water quality parameter.

For all samples it is a good practice to leave a small air space at the top of the sample bottle to allow for mixing prior to analysis.

When taking samples for microbiological analysis it is important to prevent contamination of the inside of the bottle or cap by touching with fingers or any non-sterile tools. Samples for this type of analysis should be collected before other sample types.

3.2.2 PURGING AND SAMPLING

If the well is equipped with a DWLR, the instrument should carefully be removed conforming to the instructions provided with the instrument.

Before starting purging, the technical condition of the well needs to be checked and its suitability for the insertion of a submersible pump needs to be verified. This is usually performed by inserting a metal body, similar in shape to the submersible pump, into the well. Once smooth insertion of the metal body to the required depth and its subsequent removal is performed, the submersible pump can be safely inserted and the purging operation may start.

Purging

Three purging requirements should be met before sampling can start:

- Purging should last until at least 4 to 5 times the initial well volumes are replaced
- Purging should last for a minimum of 10 minutes
- Field parameters, such as EC and ORP, should give stable readings

The time required to purge 4 to 5 times the initial well volume may be calculated for each well individually according to the following equation:

$$\text{MPT} = \frac{0.1\pi \times \phi^2 \times (D - \text{SWL})}{Q}$$

where,

MPT	=	minimum required time of purging [min]
D	=	depth of well (ground surface to bottom of well) [m]
SWL	=	depth to static water level [m]
ϕ	=	internal diameter of well [cm]
Q	=	pump discharge (limited to 100 L/min) [L/min]

The field observer must obtain the following information before starting the purging operation at the well:

- the actual static water level (SWL)
- depth and diameter of the well
- available pump discharge (limited by the maximum permissible purging rate of 100L/min)
- minimum number of initial well volumes to be replaced; a default value of 4 is suggested, but well-specific adjustments based on calculations, as per Appendix B, using static field data for the specific well, is recommended.

Note that only the SWL must be determined in the field, the other data are static and can be available before the field visit.

The observer should then calculate the minimum required time of purging (MPT). In case the calculated value is less than 10 minutes the pump discharge should be lowered to such a rate that the purging operation takes at least 10 minutes. Hence $Q \leq 0.01\pi \cdot \phi^2 \cdot (D - \text{SWL})$ [l/min]. Purging can then start for the required time (MPT).

The monitoring of the various field parameters (pH, temperature, ORP and conductivity) should start simultaneously with purging. The purging operation should continue till:

- the minimum purging time required (MPT) is exceeded, and
- all field parameters measured have stable readings for a minimum duration of 3 minutes.

The initial and final values for temperature, pH, ORP and conductivity should be recorded along with all other data related to the sampling operation.

Sampling

After the purging requirements have been fulfilled, the sampling of the desired water quality parameters can start. For this, the pump discharge must be lowered to a rate less than 0.1 L/min. before the sample containers are filled. Table 3.2 indicates parameter values for 99% purging efficiency when 5 times the well water volume are replaced.

Parameter	Value	More well-volumes required if
Well Diameter	11.4 cm	diameter larger than 11.4 cm
Transmissivity	20 m ² /day	transmissivity lower than 20 m ² /day
Specific Yield	2 %	specific yield lower than 2 %

Table 3.2: Parameter Values Giving 99% Purging Efficiency

4 GUIDELINES TO BE FOLLOWED DURING SAMPLING

4.1 GENERAL

- At least one day before sampling, make sure that all the arrangements are made as per the check list given in Chapter 2.
- Make sure that you know how to reach sampling site(s). Take help of location map for the site which shows the sample collection point with respect to prominent landmarks in the area. In case there is any deviation in the collection point, record it on the sample identification form giving reason.
- Rinse the sample container at least three times with the sample before it is filled.
- Leave a small air space in the bottle to allow mixing of sample at the time of analysis.
- Label the sample container properly, preferably by attaching an appropriately inscribed tag or label. The sample code and the sampling date should be clearly marked on the sample container or the tag.
- Complete the sample identification form (Table 5) for each sample.
- The sample identification form should be filled for each sampling occasion at a monitoring station. Note that if more than one bottle is filled at a site, this is to be registered on the same form.
- Sample identification forms should all be kept in a master file at the level II or II+ laboratory where the sample is analysed.

4.2 GROUNDWATER SAMPLING

- Samples for groundwater quality monitoring would be collected from one of the following three types of wells:
 - *Open dug wells* in use for domestic or irrigation water supply,
 - *Tube wells* fitted with a hand pump or a power-driven pump for domestic water supply or irrigation
 - *Piezometers*, purpose-built for recording of water level and water quality monitoring.
- Open dug wells, which are not in use or have been abandoned, shall not be considered as water quality monitoring station.
- Use a weighted sample bottle to collect sample from an open well about 30 cm below the surface of the water (See Figure 4.1). Do not use a plastic bucket, which is likely to skim the surface layer only.
- Samples from the production tube wells will be collected after running the well for about 5 minutes.
- Non-production piezometers should be purged using a submersible pump. The purged water volume should equal 4 to 5 times the standing water volume, before sample is collected.
- For bacteriological samples, when collected from tubewells/hand pump, the spout/outlet of the pump should be sterilised under flame by spirit lamp before collection of sample in container.

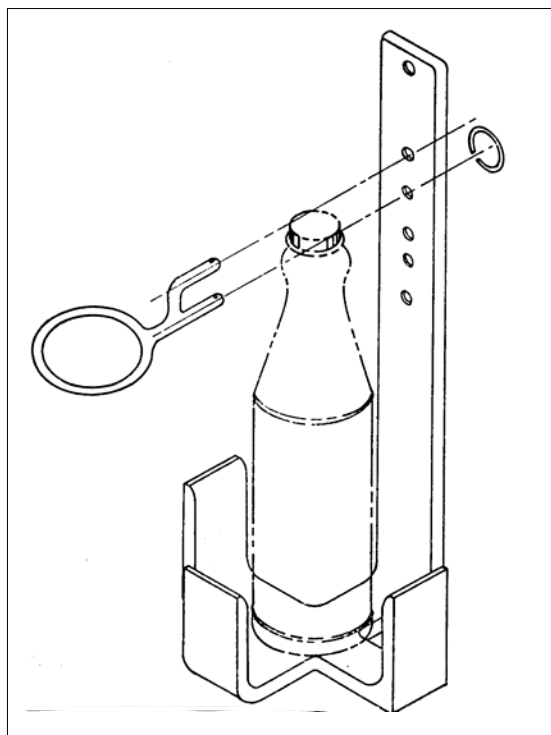

Figure 4.1:
Weighted sample bottle holder for sampling

4.3 SAMPLE IDENTIFICATION FORMS

The sample identification form provides a record of all important information concerning the sample collected. Complete the sample identification form at each monitoring site, detailing the samples that are collected at that site. Note that if more than one bottle is filled at a site, for different types of analyses, this is to be registered on the same form.

Local conditions, such as garbage in a well or visible pollution around a well as at the sampling site should be recorded on the form, at the time of sampling. Such information may be useful in analysis of data.

The form for identifying the sample and recording the field measurements and site conditions is given in Table 4.1.

Duly filled-in sample identification forms should be given to the laboratory analyst together with the samples. The forms should all be kept in a master file at the level II or II⁺ laboratory where the samples are analysed.

4.4 SAMPLE LABELLING

Label the sample container properly, preferably by attaching an appropriately inscribed tag or label. Alternatively, the bottle can be labelled directly with a water-proof marker. Information on the sample container or the tag should include:

- sample code number (identifying location)
- date and time of sampling
- source and type of sample
- pre-treatment or preservation carried out on the sample
- any special notes for the analyst
- sampler's name

4.5 SAMPLE PRESERVATION AND TRANSPORT

Preserve the collected samples as specified in Tables 1.1 and 3.1.

Samples for BOD and bacteriological analyses should be stored at a temperature below 4°C and in the dark as soon as possible after sampling. In the field this usually means placing them in an insulated cool box together with ice or cold packs. Once in the laboratory, samples should be transferred as soon as possible to a refrigerator.

If samples collected for chemical oxygen demand (COD) analysis cannot be analysed on the day of collection they should be preserved below pH 2 by addition of concentrated sulphuric acid. This procedure should also be followed for samples for ammonia nitrogen, total oxidised nitrogen and phenol analysis.

Samples which are to be analysed for the presence of metals, should be acidified to below pH 2 with concentrated nitric acid. Such samples can then be kept up to six months before they need to be analysed; mercury determinations should be carried out within five weeks, however.

After labelling and preservation, the samples should be placed in an insulated cool box for transportation (Figure 4.2). Samples should be transported to concerned laboratory (level II or II⁺) as soon as possible, preferably within 48 hours.

Analysis of bacteriological samples should be started and analysed within 24 hours of collection.

If samples are being brought to a Level I laboratory for the 'field determinations', they should be transported in less than 24 hours.

Sample code												
Observer				Agency				Project				
Date			Time			Well code						
Source of sample: <input type="checkbox"/> Open dug well <input type="checkbox"/> Hand pump <input type="checkbox"/> Tube well <input type="checkbox"/> Piezometer												
Parameter code	Container				Preservation				Treatment			
	Glass	PVC	PE	Teflon	None	Cool	Acid	Other	None	Decant	Filter	
(1) General												
(2) Bacteriological												
(3) BOD												
(4) COD, NH ₃ , TON												
(5) H Metals												
(6) Tr Organics												
Field determinations												
Temp	°C	pH		EC								µmho/cm
Odour code	(1) Odour free		(6) Septic						Colour code			
	(2) Rotten eggs		(7) Aromatic									
	(3) Burnt sugar		(8) Chlorinous									
	(4) Soapy		(9) Alcoholic									
	(5) Fishy		(10) Unpleasant									

IF WELL IS PURGED, COMPLETE BELOW:

Office Well Data			
Diameter	φ		cm
Depth	D		m
Static water level (avg)	SWL		m
Water column (D-SWL)	H		m
Initial volume well	V		L
Projected pump discharge	PQ		L/s
Projected time of purging (V/PQ)	PT		min
Field Flow Measurements			
Static water level on arrival	SWL		m
Actual pump setting			m
Purging duration			min
Pump discharge before sampling	Q		L/min
Pump discharge after sampling	Q		L/min
Volume purged	V		L
Dynamic water level	DWL		m
Field Chemical measurement			
Time at start of sampling started	T (°C)	EC(µmho/cm)	pH
+10 min			
+20 min			
+30 min			
+40 min			

Table 4.1: Sample Identification Form for Groundwater Samples

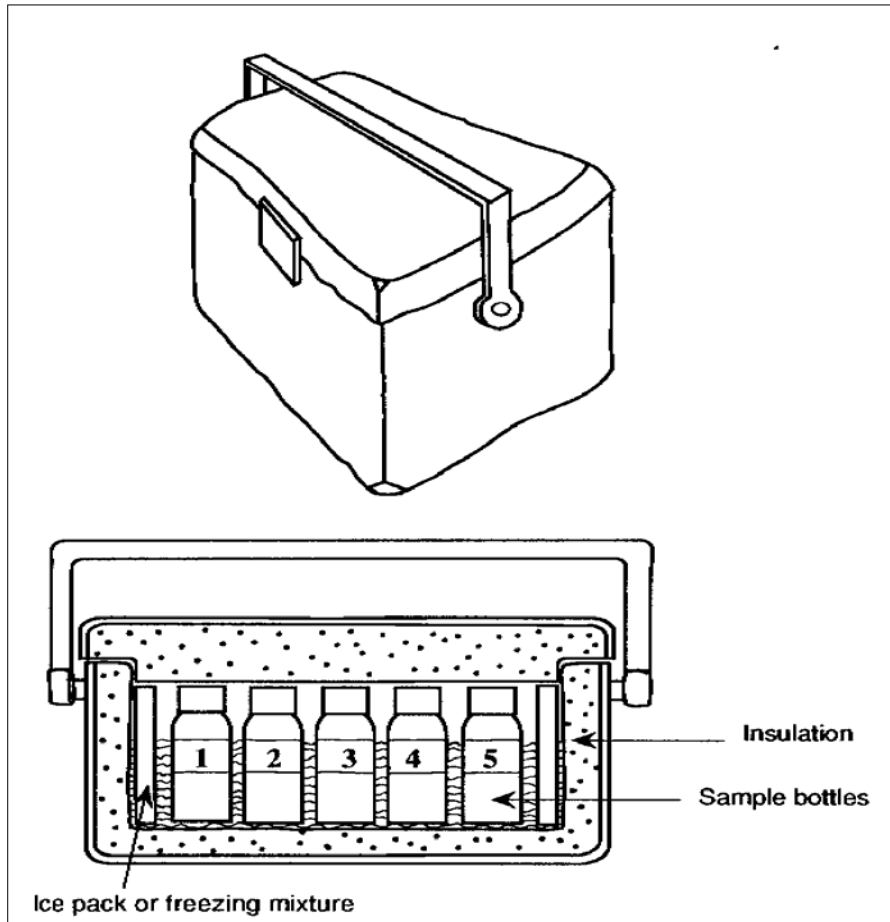

Figure 4.2: Insulated Bottle Carrier for Water Quality Samples

5 STANDARD ANALYTICAL PROCEDURES – FIELD DETERMINATIONS

5.1 GENERAL

Measurements of colour, odour, temperature, electrical conductivity and pH are considered to be 'Field Determinations' and should be made as soon as possible after collecting a sample. Measurement of these parameters can be made in the field if field meters are available. This is the best option, as the analyses will be made immediately. If samples are brought to the level II/II⁺ laboratory, the travel time should be *very* short, so that parameter values do not change between the time the sample is collected at the time of analysis.

5.2 COLOUR

Determining the colour in the field is relatively easy. Pour an aliquot of approximately 10mL of sample into a glass test tube and judge the colour observed. Assign **one** of the colour codes from Table 5.1 to the sample. In case the colour of water does not fall under code 1 to 7, select code 8 and note down the details of the colour observed. Report the colour code on the sample identification form.

Colour Code	(1) Light brown
	(2) Brown
	(3) Dark brown
	(4) Light green
	(5) Green
	(6) Dark green
	(7) Clear
	(8) Other specify

Table 5.1: Codes for Field Determination of Colour

5.3 ODOUR

Determining the odour should always be done in the field, as soon as possible after collecting a sample. After collection, fill a cleaned odourless bottle half-full of sample, insert stopper, shake vigorously for 2-3 seconds and then quickly smell the odour. Alternatively, pour an aliquot of approximately 5mL of sample into a glass test tube and judge the odour.

Assign **one** of the odour codes from Table 5.2 to the sample. In case option 10 'unpleasant' is selected please try to note down the details of the odour observed (e.g. agreeable or disagreeable). Note: Do not select option 10 if the odour observed can be classified as one in the list from 1 to 9. Report the odour code on the sample identification form.

Odour Code	(1) Odour free
	(2) Rotten eggs
	(3) Burnt sugar
	(4) Soapy
	(5) Fishy
	(6) Septic
	(7) Aromatic
	(8) Chlorinous
	(9) Alcoholic
	(10) Unpleasant

Table 5.2: Codes for Field Determination of Odour

5.4 TEMPERATURE

Water temperature should be measured in degrees Celsius, using a mercury thermometer or a thermistor. Normally, if temperature is measured electronically using a thermistor, this device is built into an instrument which is capable of making other water quality measurements (e.g., pH and EC).

Whenever possible, the temperature should be measured by directly dipping the thermometer in the natural body of water being studied. In case it is not possible, collect about 500 mL sample in a plastic or glass container and measure temperature by immersing the thermometer in the sample. Read the temperature after equilibration (no more change in the temperature reading).

Report the temperature on the sample identification form in units of degrees Celsius with 1 digit after the decimal point e.g. 13.2 °C.

5.5 pH

The most accurate method of measuring water pH in the field is by means of a portable purpose-designed meter. Such meters are normally capable of measuring pH to the nearest 0.05 of a pH unit by using a 'glass' and a 'reference' electrode (although these are often combined in a single probe).

Before measuring pH, it is necessary to calibrate the meter. This should be done at least once per day, before the first pH measurement is attempted. The procedure of this is as follows:

- i. After removing their protective caps, the electrodes are rinsed in distilled water and carefully wiped dry with soft absorbent paper. *NOTE: Care needs to be exercised here as the electrodes are very fragile.*
- ii. The electrodes are then placed in a fresh buffer solution and after following time for meter stabilisation, the pH reading of the meter is adjusted to the pH the buffer solution (normally pH = 7).
- iii. The electrodes are then rinsed again with distilled water and wiped dry.
- iv. If a pH measurement is not to be taken immediately, the electrodes should be replaced in their protective caps. Normally, the glass electrode cap is filled with distilled water before replacement to prevent the electrode drying out.
- v. Report the pH on the sample identification form in pH units showing one digit after the decimal point, e.g. 7.6.

Once calibrated, the pH meter can be used to measure the pH directly by placing the electrodes in water sample immediately after it is obtained. Care should be taken to ensure that the electrodes are rinsed with distilled water before and after each determination and that distilled water is placed into the glass electrode cap before transportation.

5.6 ELECTRICAL CONDUCTIVITY (EC)

EC can be measured in the field with a purpose-designed meter, see section 2.3. Before measuring conductivity, it is necessary to calibrate the meter. This should be carried out at least once per day, before the first measurement is taken. Calibration is achieved by determining the conductivity of a known, fresh solution of potassium chloride and adjusting the meter accordingly. In order to ensure the conductivity reading is accurate, it is necessary to adjust the conductivity reading to compensate for temperature changes. In most modern meter this is done automatically.

Once calibrated, the conductivity of the water can be measured by immersing electrode in a sample of water as soon as it is taken. It is important to remember that conductivity meters often take some minutes to stabilise. The reading must, therefore, be taken after this stabilisation has occurred. Report the EC at 25°C in $\mu\text{mhos/cm}$ with no figure after the decimal point, e.g. 1135 $\mu\text{mhos/cm}$.

5.7 OXIDATION REDUCTION POTENTIAL (ORP)

ORP can be measured in the field with a purpose-designed platinum (Pt) electrode and meter in mV. Before measuring the ORP it is necessary to calibrate the meter. This should be carried out at least once per day, before the first measurement is taken. Calibration is achieved by the determining the ORP (Zobell's solution). For correct interpretation, simultaneous recording of the temperature of the water sample is necessary.

Once calibrated, the ORP of the water can be measured by immersing the electrode in a sample of water as soon as it is taken. Contact with air should be prevented as much as possible. It is important to remember that an ORP electrode often takes some minutes to stabilise, the reading must, therefore, be taken after this stabilisation has occurred.

6 GUIDELINES ON STANDARD ANALYTICAL PROCEDURES

The '*Guidelines on Standard Analytical Procedures for Water Analyses, May 1999*' for detailed measurement procedures including preparation of reagents are appended (Appendix A) for the following analyses:

- Odour
- Temperature
- pH
- Electrical Conductivity
- Oxidation Reduction Potential (ORP)

APPENDIX A STANDARD ANALYTICAL PROCEDURES

OD	ODOUR
Method:	QUALITATIVE HUMAN RECEPTOR
ID: 1.19	Version: 1

Procedure

- a. As soon as possible after collection of sample, fill a cleaned odourless bottle half – full of sample, insert stopper, shake vigorously for 2 to 3 seconds and then quickly observe the odour. The sample should be at ambient temperature.
- b. Report the odour as: odour free, rotten egg, burnt sugar, soapy, fishy, septic, aromatic, chlorinous, alcoholic odour or any other specific odour. In case it is not possible to specify the exact nature of odour, report as agreeable or disagreeable.

T	TEMPERATURE
Method:	MERCURY THERMOMETER
ID: 1.27	Version: 1

Apparatus

Mercury thermometer having a scale marked for every 0.1°C.

Procedure

- a. Immerse thermometer in the sample up-to the mark specified by the manufacturer and read temperature after equilibration.
- b. When a temperature profile at a number of different depths is required a thermistor with a sufficiently long lead may be used.

Reporting

Report the temperature in units of degree Celsius with 1 digit after the decimal point, e.g. 13.2 °C.

EC	ELECTRICAL CONDUCTIVITY
Method:	CONDUCTIVITY CELL POTENTIOMETRIC
ID: 1.10	Version: 1

Apparatus

- Conductivity meter* capable of measuring conductivity with an error not exceeding 1% or 0.1mS/m whichever is greater.
- Conductivity cell*, Pt electrode type. For new cells not already coated and old cell giving erratic readings platinise according to the following procedure. Clean the cell with chromic – sulphuric acid cleaning mixture. Prepare platinising solution by dissolving 1g chloroplatinic acid, H₂PtCl₆.6H₂O and 12mg lead acetate in 100 mL distilled water. Immerse electrodes in this solution and connect both to the negative terminal of a 1.5V dry cell battery (in some meters this source is built in). Connect the positive terminal to a platinum wire and dip wire into the solution. Continue electrolysis until both cell electrodes are coated with platinum black.

Reagent

- Conductivity water* – use distilled water boiled shortly before use to minimise CO₂ content. Electrical conductivity must be less than 0.1 µmho/cm.
- Standard potassium chloride solution*, KCl, 0.01M, conductivity 1412 µmho/cm at 25°C. Dissolve 745.6mg anhydrous KCl (dried 1 hour at 180°C) in conductivity water and dilute to 1000 mL. This reference solution is suitable when the cell has a constant between 1 and 2 per cm.

Procedure

- Rinse conductivity cell with at least three portions of 0.01M KCl solution. Measure resistance of a fourth portion and note temperature.
- In case the instrument indicates conductivity directly, and has internal temperature compensation, after rinsing as above, adjust temperature compensation dial to 0.0191/ °C and with the probe in standard KCl solution, adjust meter to read 1412 µmho/cm. Continue at step d.
- Compute the cell constant*, K_C according to the formula:

$$K_C = \frac{1412}{C_{KCl}} \times [0.0191(t - 25) + 1]$$

where:

K_C = the cell constant, 1/cm

C_{KCl} = measured conductance, µmho

t = observed temperature of standard KCl solution, °C

The value of temperature correction [0.0191 x (t-25)+1] can be read from Table 1.

- d. Rinse cell with one or more portions of sample. The level of sample aliquot must be above the vent holes in the cell and no air bubbles must be allowed inside the cell. Adjust the temperature of sample to about 25°C (outside a temperature range of 20 – 30°C, error increases as the sample temperature increasingly deviates from the reporting temperature of 25°C). Read sample conductivity and note temperature to nearest 0.1°C.
- e. Thoroughly rinse the cell in distilled water after measurement, keep it in distilled water when not in use.

Calculation

- a. When sample conductivity is measured with instruments having temperature compensation, the readout automatically is corrected to 25°C. If the instrument does not have internal temperature compensation, conductivity at 25°C is:

$$\text{Electrical Conductivity } (\mu\text{mhos/cm}) = \frac{C_M \times K_C}{0.0191(t - 25) + 1}$$

where:

- K_C = the cell constant, 1/cm
 C_M = measured conductance of the sample, μmho
 t = observed temperature of sample, °C

The value of temperature correction $[0.0191 \times (t-25)+1]$ can be read from Table 8.

- b. Record the meter reading, the unit of measurement and the temperature of the sample at the time of reading. Report the electrical conductivity at 25°C. Report conductivity preferably in $\mu\text{mho/cm}$. Use values in Table 9 for conversion of units.

T (°C)	0.0	0.1	0.2	0.3	0.4	0.5	0.6	0.7	0.8	0.9
15	0.810	0.812	0.814	0.816	0.818	0.820	0.821	0.823	0.825	0.827
16	0.829	0.831	0.833	0.835	0.837	0.839	0.840	0.842	0.844	0.846
17	0.848	0.850	0.852	0.854	0.856	0.858	0.859	0.861	0.863	0.865
18	0.867	0.869	0.871	0.873	0.875	0.877	0.878	0.880	0.882	0.884
19	0.886	0.888	0.890	0.892	0.894	0.896	0.897	0.899	0.901	0.903
20	0.905	0.907	0.909	0.911	0.913	0.915	0.916	0.918	0.920	0.922
21	0.924	0.926	0.928	0.930	0.932	0.934	0.935	0.937	0.939	0.941
22	0.943	0.945	0.947	0.949	0.951	0.953	0.954	0.956	0.958	0.960
23	0.962	0.964	0.966	0.968	0.970	0.972	0.973	0.975	0.977	0.979
24	0.981	0.983	0.985	0.987	0.989	0.991	0.992	0.994	0.996	0.998
25	1.000	1.002	1.004	1.006	1.008	1.010	1.011	1.013	1.015	1.017
26	1.019	1.021	1.023	1.025	1.027	1.029	1.030	1.032	1.034	1.036
27	1.038	1.040	1.042	1.044	1.046	1.048	1.049	1.051	1.053	1.055
28	1.057	1.059	1.061	1.063	1.065	1.067	1.068	1.070	1.072	1.074
29	1.076	1.078	1.080	1.082	1.084	1.086	1.087	1.089	1.091	1.093
30	1.095	1.097	1.099	1.101	1.103	1.105	1.106	1.108	1.110	1.112
31	1.114	1.116	1.118	1.120	1.122	1.124	1.125	1.127	1.129	1.131
32	1.133	1.135	1.137	1.139	1.141	1.143	1.144	1.146	1.148	1.150
33	1.152	1.154	1.156	1.158	1.160	1.162	1.163	1.165	1.167	1.169
34	1.171	1.173	1.175	1.177	1.179	1.181	1.182	1.184	1.186	1.188
35	1.190	1.192	1.194	1.196	1.198	1.200	1.201	1.203	1.205	1.207

Table 8: Value of $[0.0191 \times (T-25) + 1]$ for Temperature Correction in EC Measurement

Multiply	By	to obtain
μS/m	0.01	μmho/cm
mS/cm	10	μmho/cm
mS/cm	1000	μmho/cm
μS/cm	1	μmho/cm
mmho/cm	1000	μmho/cm

Table 9: Conversion table for units of electrical conductivity

Note

1S = 1mho

Reporting

Report electrical conductivity in units of μmho/cm, with 0 digits after the decimal point, e.g. 1135 μmho/cm. Use Table 9 for conversion of units.

pH	pH
Method:	POTENTIOMETRIC
ID: 1.21	Version: 1

Apparatus

- pH meter* with temperature compensating device, accurate and reproducible to 0.1 pH unit with a range of 0 to 14.
- Reference electrode* preferably with quartz liquid junction. Follow manufacturer's instructions on use and care of the reference electrode. Refill non-sealed electrodes with correct electrolyte to proper level and make sure junction is properly wetted.
- Glass electrode*. Follow manufacturer's instructions on use and care of electrode.

Reagents

- Potassium hydrogen phthalate buffer, 0.05M, pH 4.00*. Dissolve 10.12 g $\text{KHC}_8\text{H}_4\text{O}_4$ (potassium hydrogen phthalate) in 1000 mL freshly boiled and cooled distilled water
- 0.025M Potassium dihydrogen phosphate + 0.025M disodium hydrogen phosphate buffer, pH 6.86*. Dissolve 3.387 g KH_2PO_4 + 3.533 g Na_2HPO_4 in 1000 mL freshly boiled and cooled distilled water
- 0.01M sodium borate decahydrate (borax buffer), pH = 9.18*. Dissolve 3.80 g $\text{Na}_2\text{B}_4\text{O}_7 \cdot 10\text{H}_2\text{O}$ in 1000 mL freshly boiled and cooled distilled water.
- Store buffer solutions in polyethylene bottles. Replace buffer solutions every 4 weeks.

Procedure

- Remove electrodes from storage solution, rinse, blot dry with soft tissue, place in initial buffer solution and standardise pH meter according to manufacturer's instructions.
- Remove electrodes from the first buffer, rinse thoroughly with distilled water, blot dry and immerse in second buffer preferably of pH within 2 pH units of the pH of the sample. Read pH, which should be within 0.1 unit of the pH of the second buffer.
- Determine pH of the sample using the same procedure as in (b) after establishing equilibrium between electrodes and sample. For buffered samples this can be done by dipping the electrode into a portion of the sample for 1 min. Blot dry, immerse in a fresh portion of the same sample, and read pH.
- With dilute poorly buffered solutions, equilibrate electrodes by immersing in three or four successive portions of the sample. Take a fresh sample to measure pH.
- Stir the sample gently while measuring pH to insure homogeneity.

Reporting

Report results in pH units with 1 digit after the decimal point, e.g. 7.6.

ORP	OXIDATION REDUCTION POTENTIAL
Method:	POTENTIOMETRIC WITH PT-ELECTRODE
ID: 1.46	Version: 1

Apparatus

- pH meter or other type of high impedance potentiometer that can measure millivolt (mV). A scale reading up to 1000 mV is sufficient for most cases.
- Reference electrode* consisting of a half-cell providing a constant electrode potential, commonly a calomel or a silver:silver-chloride electrode, preferably with quartz liquid junction. Follow manufacturer's instructions on use and care of the reference electrodes. Refill non-sealed electrodes with correct electrolyte to proper level and make sure junction is properly wetted.
- Oxidation-reduction indicator electrode.* Platinum (Pt) electrode is commonly used, it usually comes as a wire type electrode. Electrode surface must be metal coloured. In case electrode surface is dirty (black) clean by using 400-600 grit wet/dry carborundum paper.

Reagents

- ZoBell's Solution or standard redox solution.* Use either commercially available solution or prepare in laboratory as follows. Dissolve 1.4080 g potassium ferrocyanide ($K_4Fe(CN)_6 \cdot 3H_2O$) + 1.0975g potassium ferricyanide ($K_3Fe(CN)_6$) + 7.4555g potassium chloride (KCl) in 1000mL distilled water. If stored in the dark in a refrigerator the solution is stable for several months.

Procedure

- Equilibrate ZoBell's solution to the temperature of the sample. Remove electrodes from storage solution, rinse, blot dry with soft tissue, place in ZoBell's solution. Turn meter on using the millivolt mode. Measure temperature of the ZoBell solution.
- Allow several minutes for electrode equilibration then record reading to nearest millivolt. Check reading against theoretical value of ZoBell's solution and measured temperature, see Table 10 below. Record as Eh_{ZoBell} (mV).
- If reading is more than $\pm 10mV$ from the theoretical value replace ZoBell solution with fresh portion. Repeat the reading. If this procedure fails then polish the Pt electrode gently with carborundum paper to obtain a fresh metal surface. Rinse the electrode thoroughly and recheck the reading with, again, a fresh portion of ZoBell's solution.
- Rinse the electrodes thoroughly with sample water and immerse them in the sample. Let equilibrate, this may take a few minutes, and record as $Eh_{observed}$ (mV). Also record temperature of the sample. Repeat with a second sample portion. Successive readings varying less than around 20mV over 10 minutes are adequate for most purposes.

Calculation

$$Eh_{\text{sample}} = Eh_{\text{observed}} + Eh_{\text{ZoBell/theoretical}} - Eh_{\text{Zobell}} \quad (\text{mV})$$

where:

Eh_{sample} = Oxidation reduction potential of the sample relative to the standard hydrogen electrode, mV

Eh_{observed} = ORP observed relative to reference electrode (see procedure *d.*), mV

$Eh_{\text{Zobell-theoretical}}$ = Theoretical ORP of reference electrode and ZoBell's solution, relative to standard hydrogen electrode. Read from Table 10 below, mV

Eh_{Zobell} = Observed ORP of ZoBell's solution relative to reference electrode (see procedure *b.*), mV

Note

T (°C)	E (mV)	T (°C)	E (mV)
1	481	16	448
2	479	17	446
3	476	18	443
4	474	19	441
5	472	20	439
6	470	21	437
7	468	22	435
8	465	23	432
9	463	24	430
10	461	25	428
11	459	26	426
12	457	27	424
13	454	28	421
14	452	29	419
15	450	30	417

Table 10: *Theoretical value of ZoBell's solution (mV) for different temperatures*

Reporting

Report results in units of mV with 0 digits after the decimal point, e.g. 55 mV.

Appendix B

Specifications for Submersible Pumps

The specifications for capacity and discharge of submersible pumps depend largely on the situation in the field (depth of the water table, hydraulic characteristics of the aquifer, diameter of the well, initial thickness of the water column, time available for the sampling procedure, etc.). The effect of varying field conditions on the required pump capacity has been calculated and is presented in Table B-1. In these calculations the following assumptions made:

- pump heat loss is 20% (efficiency = 80%)
- specific yield is 2%
- Darcy-Weisbach coefficient is 0.04 (for both casing and delivery tube)
- transition losses add up to 1 m
- height of delivery point above ground is 2 m
- diameter of the delivery tube is 3.81cm (1.5 inch)
- depth of pump below the dynamic water level is 2 m

The set-up of the well under purging is presented in Figure B-1. In the calculations it is assumed that mixing of well water and aquifer water is complete and instantaneous. Equation B-1 gives the mass concentration balance for the well under purging (change in mass equals inflow minus outflow). This equation can be re-arranged into B-2. Assuming the factor Q_i/V to be constant, the solution to B-2 is given in equation B-3. The reciprocal of the Q_i/V is the relaxation time T_C ; the smaller T_C , the faster the well assumes the aquifer concentration. The fraction of aquifer water in the well at time t is given by equation B-4.

$$\frac{d}{dt} (Vc) = Q_i c_i - Q_o c \quad (\text{B-1})$$

$$\frac{d}{dt} (c - c_i) + (c - c_i) \frac{Q_i}{V} = 0 \quad (\text{B-2})$$

$$\frac{c - c_i}{c_o - c_i} = \exp\left(-\frac{Q_i}{V} \cdot t\right) = \exp\left(-\frac{t}{T_C}\right) \quad (\text{B-3})$$

$$C = 1 - \exp\left(-\frac{t}{T_C}\right) \quad (\text{B-4})$$

In the solution of the differential equation it has been assumed that $T_C = V/Q_i$ is constant. This is not entirely correct. The actual value of T_C at time t is given by equation B-5, where the effect of draw-down has been estimated with the help of the Cooper-Jacob, equation B-6. From B-5 it is observed that the actual value of T_C is slightly smaller than V_o/Q_o . Hence, by estimating T_C from V_o/Q_o , the required pumping time to obtain a certain purging efficiency is on the conservative side.

$$T_C = \frac{V}{Q_i} = \frac{V_o}{Q_o} \cdot \frac{\left(1 - \frac{s}{H}\right)}{\left(1 - \frac{r^2}{4T} \cdot \frac{1}{t}\right)} \quad (\text{B-5})$$

$$s = \frac{2.3Q_0}{4\pi T} 10 \log \frac{2.25Tt}{r^2 S} \quad (\text{B-6})$$

where:

V	=	volume of water in well during purging	[m ³]
V ₀	=	volume of water in well when purging starts	[m ³]
C	=	actual concentration in well	[g/m ³]
C ₀	=	initial concentration in well	[g/m ³]
C _i	=	concentration in aquifer water	[g/m ³]
Q ₀	=	pump discharge	[m ³ /s]
Q _i	=	flow of aquifer water into the well	[m ³ /s]
t	=	time of purging	[s]
T _c	=	relaxation time	[s]
s	=	draw-down	[m]
H	=	initial height of water column	[m]
r	=	internal radius of well	[m]
T	=	aquifer transmissivity	[m ² /s]
S	=	specific yield	[-]

These equations are dimensionally homogenous, so any consistent system of units may be used.

The required capacity of the pump is calculated by B-7. It computes the product of discharge (Q) and the total dynamic head consisting of total head (h_d + d + s), friction head in tubes (h_{ft}), casing (h_{fc}), bends (h_b) and the velocity head (v_t²/2g).

$$C_p = \left(\rho \cdot g \cdot Q \left(h_d + d + s + h_{ft} + h_{fc} + h_t + \frac{V_t^2}{2g} \right) \right) / \eta \quad (\text{B-7})$$

with:

$$h_{ft} = f_c \cdot \frac{d_p + s + d + h_d}{2r_t} \cdot \frac{V_t^2}{g}; \quad V_t = \frac{Q}{\pi r_t^2}$$

$$h_{fc} = f_c \cdot \frac{H - s - d_p}{2r} \cdot \frac{v^2}{g}; \quad v = \frac{Q}{\pi r^2}$$

where:

C_p	=	Pump capacity	[W]
Q	=	discharge	[m ³ /s]
h_d	=	above - ground lift	[m]
d	=	depth to static water level	[m]
s	=	draw-down	[m]
d_p	=	depth of pump below dynamic water level	[m]
h_t	=	height loss in transitions (bends etc.)	[m]
v_t	=	stream velocity in delivery tube	[m/s]
v	=	stream velocity in well	[m/s]
h_{ft}	=	friction loss in tubes	[m]
h_{fc}	=	friction loss in casing	[m]
f_c	=	Darcy-Weisbach coefficient of well casing	[-]
f_t	=	Darcy-Weisbach coefficient of delivery tube	[-]
r	=	internal radius of well	[m]
r_t	=	radius of delivery tube	[m]
g	=	acceleration due to gravity (9.81 m/s ²)	[m/s ²]
η	=	pump efficiency	[-]
ρ	=	density of water	[kg/m ³]

These equations are applicable in metric system only.

A.1 Pump discharge

Figure B-2 shows the effect of pumping time on purging efficiency for different pump discharges. As expected, purging efficiency increases with pumping time and pump discharge applied. This figure can be used to select the appropriate pump discharge for a required purging time.

A.2 Pump capacity

The required pump capacity (in terms of power consumption) is a function of the dynamic lift head of the water in the well, the discharge rate needed to obtain the desired purging efficiency within the time available and the heat loss of the pump. Table B-1 presents the conditions used in the calculations. The dynamic head is a function of the depth to the static water, the draw-down caused by pumping and a few other factors, like friction in tubing, as listed in equation B-7. Figure B-6 shows the build up of the dynamic head for various depths to static water level (SWL). As shown, all factors except friction loss in casing and the velocity head have practical importance at small depths to SWL. For greater depths to SWL, only the depth to SWL itself is contributing significantly to the dynamic head (all other factors become relatively unimportant also caused by the decline in Q).

Figure B-3 shows the pump capacity as a function of static water level depth. The curve shows a maximum pump capacity at moderate depths to SWL. At lower depths to SWL the pump capacity requirement is relatively low because of limited lift head. At higher depths to SWL the pump capacity requirement is also relatively low because of a low discharge needed to purge the small initial well volume. This figure also shows the effect of purging time. In order to decrease the purging time by 25% (say from 20 to 15 minutes) a 45% more powerful pump is needed (1.6 instead of 1.1 hp). This disproportionate increase is caused by the additional draw-down resulting in increased lift head. This effect will be larger in aquifers with lower transmissivity.

Figure B-4 shows that at higher transmissivities the required discharge and capacity of the pump decreases.

Figure B-5 shows that a larger well diameter requires a larger capacity pump. The required capacity increases almost quadratic with the diameter. The purpose build piezometers under Hydrology Project are relatively large in diameter. Approximately 30% of the wells have or will have a diameter of 11.4 cm (4.5 inch) whereas 70% has or will have a diameter of 15.2 cm (6 inch). In many countries in Europe and the USA a diameter of 2 to 2.5 inch is common for this type of monitoring piezometers. From a monitoring point of view one can state that the smaller the diameter the better. For practical reasons (drilling, availability of material and experience of contractors etc.) however, a larger diameter may be preferred.

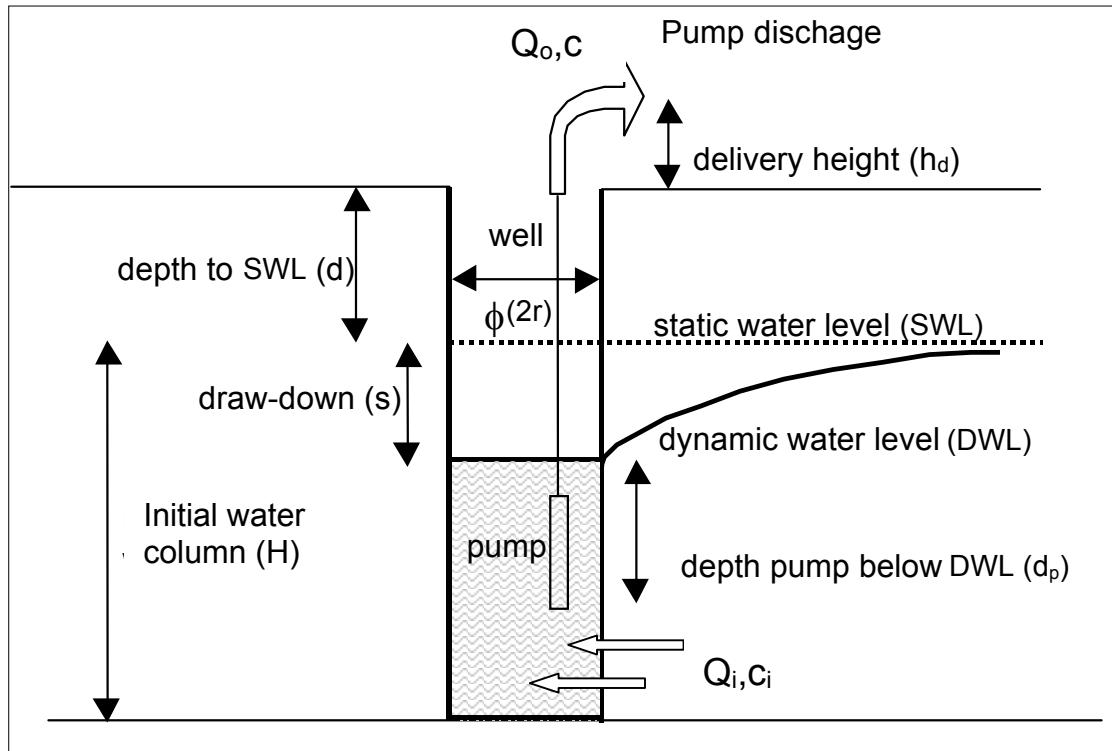

Figure B-1: Schematic Presentation of Well Under Purging (pumping) Operation

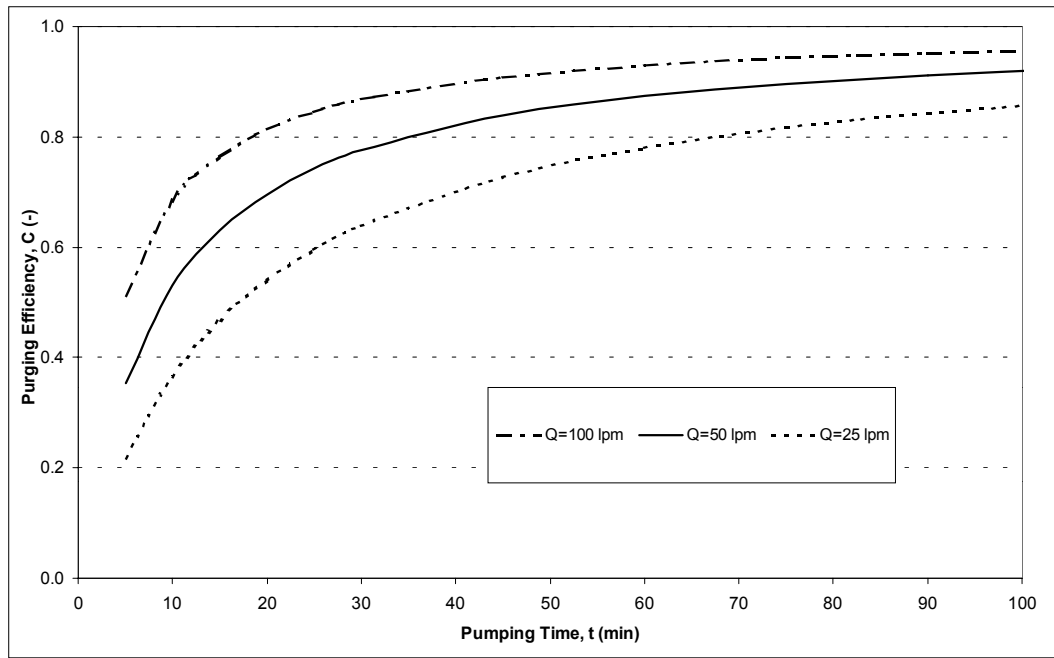

Figure B-2: Purging Efficiency as a Function of Pumping Time for Different Pump Discharges. Conditions: Depth to SWL=40 m, Well Depth=90 m, T=20 m²/day, S=2%, Pump Efficiency=0.8, φ=10 cm(4”), f_c=f_t=0.04

Conditions	Field	Initial water column (H)	(m)	85	80	70	60	50	40	30	20	10	5	3
		Equipment	Depth to static water level (d)	(m)	5	10	20	30	40	50	60	70	80	85
Calculations	Transmissivity (T)	(m ² /d)	20	20	20	20	20	20	20	20	20	20	20	
	Specific yield (S)	(-)	0.02	0.02	0.02	0.02	0.02	0.02	0.02	0.02	0.02	0.02	0.02	
	Well Diameter (φ)	(inch)	4	4	4	4	4	4	4	4	4	4	4	
	Equipment	Depth of pump below dynamic water level (dp)	(m)	2	2	2	2	2	2	2	2	2	2	2
	Height of delivery above ground level (hd)	(m)	2	2	2	2	2	2	2	2	2	2	2	
	Head loss in transitions and bends (ht)	(m)	1	1	1	1	1	1	1	1	1	1	1	
	Tube Diameter	(inch)	1.5	1.5	1.5	1.5	1.5	1.5	1.5	1.5	1.5	1.5	1.5	
	Darcy-Weisbach coef. for casing (f _c)	(-)	0.04	0.04	0.04	0.04	0.04	0.04	0.04	0.04	0.04	0.04	0.04	
	Darcy-Weisbach coef. for delivery tube (f _t)	(-)	0.04	0.04	0.04	0.04	0.04	0.04	0.04	0.04	0.04	0.04	0.04	
	Chol's	Pumping Time (t)	(min)	30	30	30	30	30	30	30	30	30	30	30
	Pump Discharge (Q)	(lpm)	143.7	136.1	119.0	102.0	85.0	67.9	50.9	34.0	17.0	8.5	5.1	
	Initial Well Volume	(l)	689	648	567	486	405	324	243	162	81	41	24	
	No. of Initial Volumes Purged	(-)	6.3	6.3	6.3	6.3	6.3	6.3	6.3	6.3	6.3	6.3	6.3	
Draw-down (s)	(m)	8.1	7.6	6.7	5.7	4.8	3.8	2.9	1.9	1.0	0.5	0.3		
Dynamic Head	(m)	20.1	24.2	32.2	40.5	48.9	57.5	66.2	75.1	84.0	88.5	90.3		
Purging efficiency (C)	(-)	0.85	0.85	0.85	0.85	0.85	0.85	0.85	0.85	0.85	0.85	0.85		
Velocity in casing (v)	(m/s)	0.098	0.093	0.082	0.070	0.058	0.047	0.035	0.023	0.012	0.006	0.003		
Velocity in delivery tube (Vt)	(m/s)	2.101	1.991	1.741	1.491	1.243	0.993	0.745	0.497	0.248	0.124	0.074		
Friction head in casing (h _{fc})	(m)	0.01	0.01	0.01	0.01	0.00	0.00	0.00	0.00	0.00	0.00	0.00		
Friction head in delivery tube (h _{ft})	(m)	3.80	3.32	2.38	1.63	1.06	0.62	0.32	0.13	0.03	0.01	0.00		
Height of delivery above ground level (hd)	(m)	2.00	2.00	2.00	2.00	2.00	2.00	2.00	2.00	2.00	2.00	2.00		
Head loss in transitions and bends (ht)	(m)	1.00	1.00	1.00	1.00	1.00	1.00	1.00	1.00	1.00	1.00	1.00		
Pump Capacity (efficiency 80% assumed)	(HP)	0.80	0.91	1.07	1.15	1.15	1.08	0.94	0.71	0.40	0.21	0.13		
Pump Capacity (efficiency 80% assumed)	(W)	599	682	795	855	861	809	699	528	295	155	95		

After 30 minutes of pumping, 85% of the water pumped originates from the aquifer and 15% from stagnant well water.

Table B-1: Pump Capacity in a 90 m-deep, 100mm Diameter Well with Varying Depths to Static Water Level

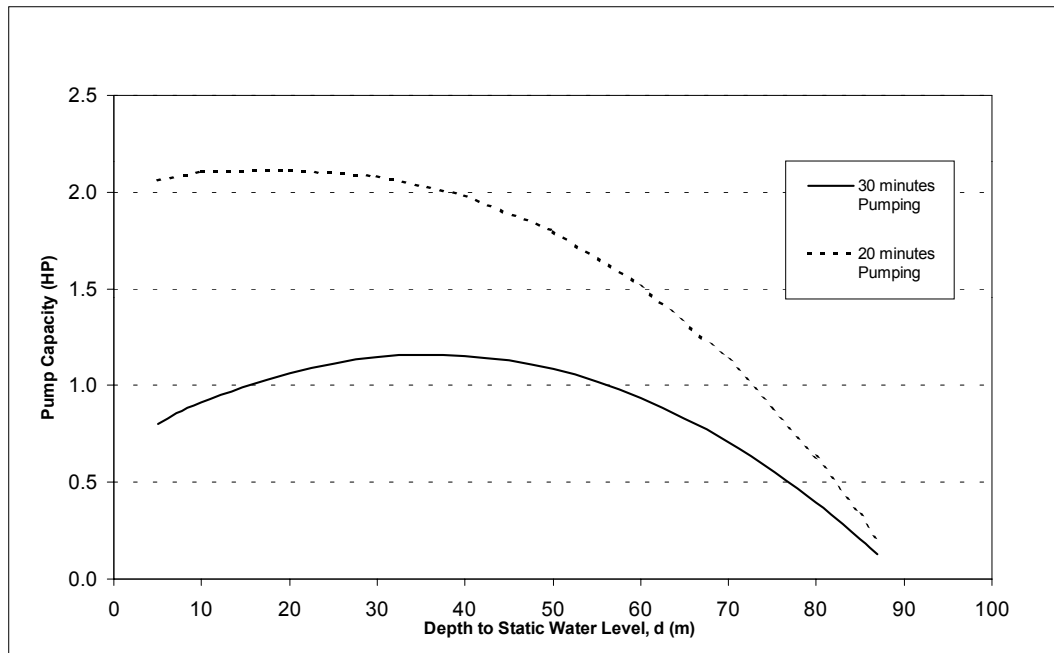

Figure B-3: Pump Capacity (in hp) required to obtain a 99% Purging Efficiency as a Function of Depth to the Static Water Level and Purging time. Conditions: Well Depth=90 m, $T=20 \text{ m}^2/\text{day}$, $S=2\%$, Pump Efficiency=0.80, $\phi=10 \text{ cm (4")}$, $f_c=f_R=0.04$

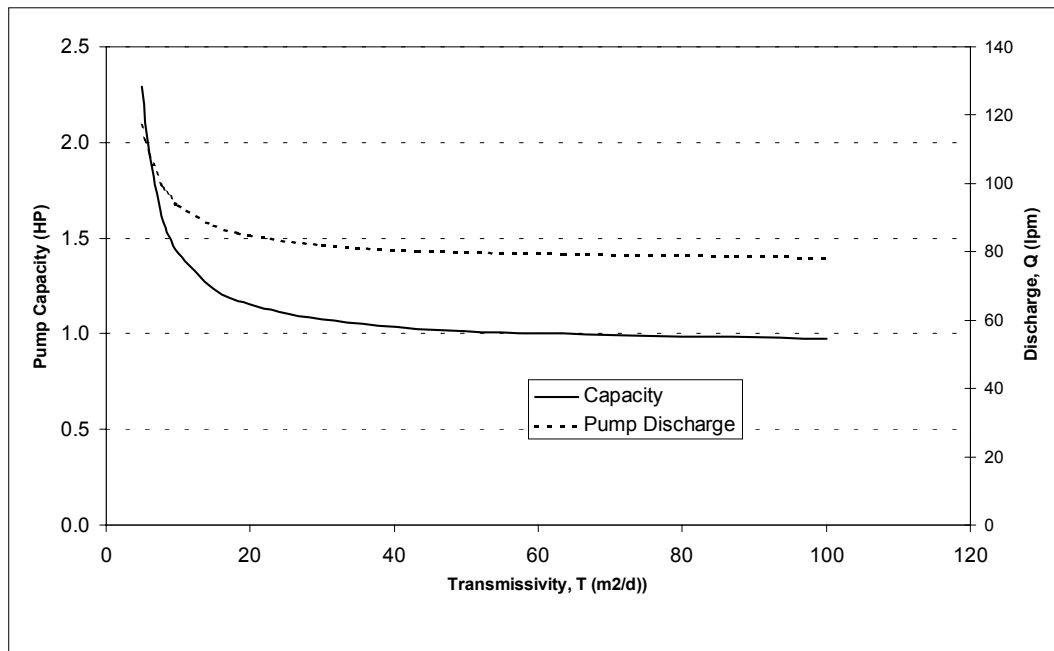

Figure B-4: Pump Capacity, Discharge and related Number of initial Well Volumes Required to Obtain 99% Purging Efficiency after 20 minutes as a Function of Aquifer Transmissivity. Conditions: Depth to SWL=40 m, Well Depth=90 m, $\phi=10 \text{ cm (4")}$, Pump Efficiency=0.80, $S=2\%$, $f_c=f_t=0.04$

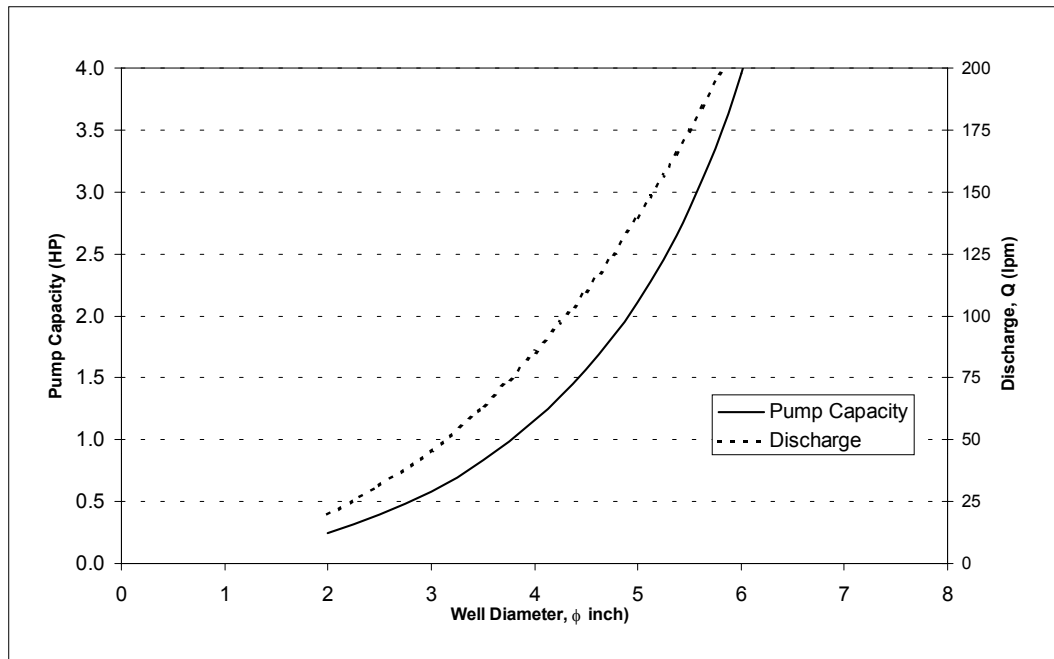

Figure B-5: Pump capacity (in hp) and discharge required to obtain 99% purging efficiency after 20 minutes as a function of well diameter. Conditions: Depth to SWL=40 m, Well Depth=90 m, $T=20 \text{ m}^2/\text{day}$, $S=2\%$, Pump Efficiency = 0.80, $f_c=f_t=0.04$

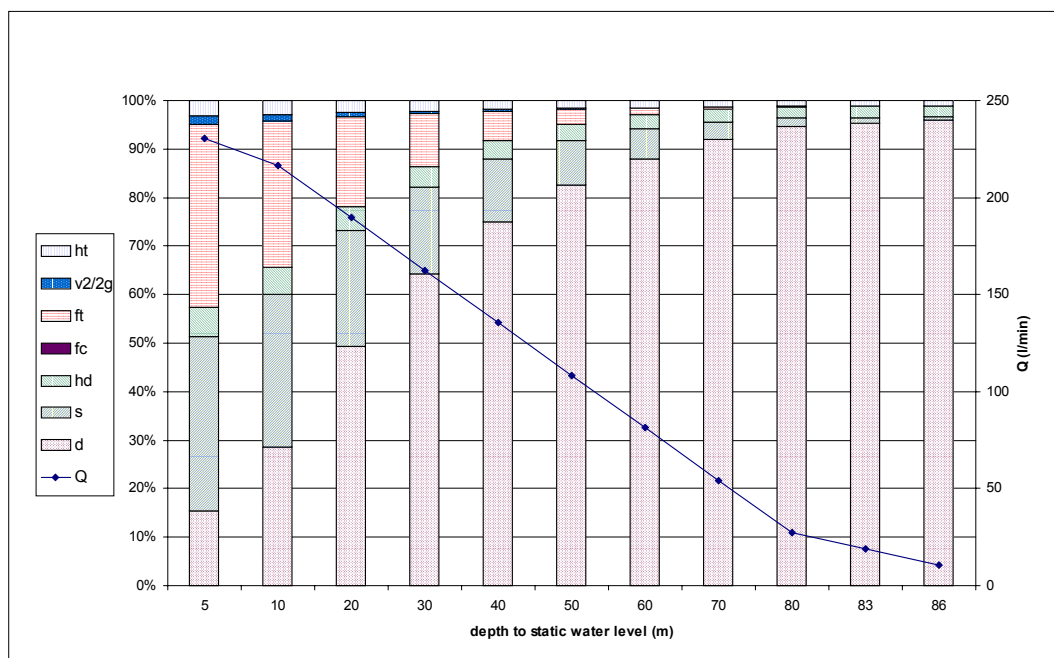

Figure B-6: Relative Importance of various Components contributing to the Dynamic Head of a 90 m Deep Well for various SWL Equipment Specification for Submersible Pump